

# KTR-Präzisions-Wellengelenke G und GD

Nach DIN 808 mit Gleitlagerung



Piktogrammlegende ist auf dem Klapper am Umschlag zu finden



Präzisions-Einfachgelenk G

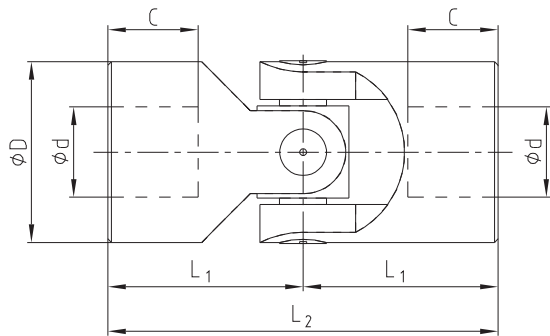

Präzisions-Doppelgelenk GD

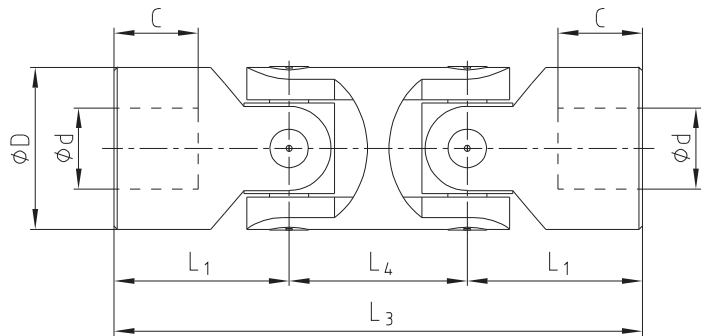

Fertigbohrungen:

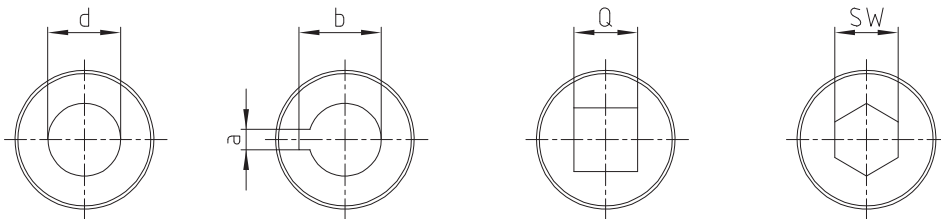

Bauart G und GD																
Bauarten und Größe															Gewicht [kg]	
Größe G	DIN-Bezeichnung G	Größe GD	DIN-Bezeichnung GD	d (H7)	D	L <sub>2</sub>	L <sub>1</sub>	C	L <sub>4</sub>	L <sub>3</sub>	a (JS9)	b	Q (H10)	SW (H10)	G	GD
01 G	E6 x 16-G	01 GD	D6 x 16-G	6	16	34	17	8	22	56	2	7,0	6	6	0,05	0,08
02 G	E8 x 16-G	02 GD	D8 x 16-G	8	16	40	20	11	22	62	2	9,0	8	8	0,05	0,08
03 G	E10 x 22-G	03 GD	D10 x 22-G	10	22	48	24	12	26	74	3	11,4	10	10	0,10	0,15
04 G	E12 x 25-G	04 GD	D12 x 25-G	12	25	56	28	13	30	86	4	13,8	12	12	0,16	0,25
05 G	E14 x 28-G	05 GD	D14 x 28-G	14	28	60	30	14	36	96	5	16,3	14	14	0,20	0,40
1 G	E16 x 32-G	1 GD	D16 x 32-G	16	32	68	34	16	37	105	5	18,3	16	16	0,30	0,45
2 G	E18 x 36-G	2 GD	D18 x 36-G	18	36	74	37	17	40	114	6	20,8	18	18	0,45	0,70
3 G	E20 x 42-G	3 GD	D20 x 42-G	20	42	82	41	18	47	129	6	22,8	20	20	0,60	1,00
4 G	E22 x 45-G	4 GD	D22 x 45-G	22	45	95	47,5	22	50	145	6	24,8	22	22	0,95	1,55
5 G	E25 x 50-G	5 GD	D25 x 50-G	25	50	108	54	26	55	163	8	28,3	25	25	1,20	2,00
6 G	E30 x 58-G	6 GD	D30 x 58-G	30	58	122	61	29	68	190	8	33,3	30	30	1,85	2,90
6 G1	E32 x 58-G	6 GD1	D32 x 58-G	32	58	130	65	33	68	198	10	35,3	30	30	2,00	3,00
7 G	E35 x 70-G	7 GD	D35 x 70-G	35	70	140	70	33	72	212	10	38,3	-	-	3,15	4,75
8 G	E40 x 80-G	8 GD	D40 x 80-G	40	80	160	80	38	85	245	12	43,3	-	-	4,60	7,20
9 G	E50 x 95-G	9 GD	D50 x 95-G	50	95	190	95	46	100	290	14	53,8	-	-	7,60	12,0

Bestell- beispiel:	04 G	Ø12	Ø12 Nute DIN
	Wellengelenkgröße/-bauart	Fertigbohrung (H7)	Fertigbohrung (H7), Passfedernute nach DIN 6885 Bl. 1 (JS9)