

KTR-Präzisions-Wellengelenke H und HD

Nach DIN 808 mit Nadellagerung



Piktogrammlegende ist auf dem Klapper am Umschlag zu finden



Präzisions-Einfachgelenk H

Präzisions-Doppelgelenk HD

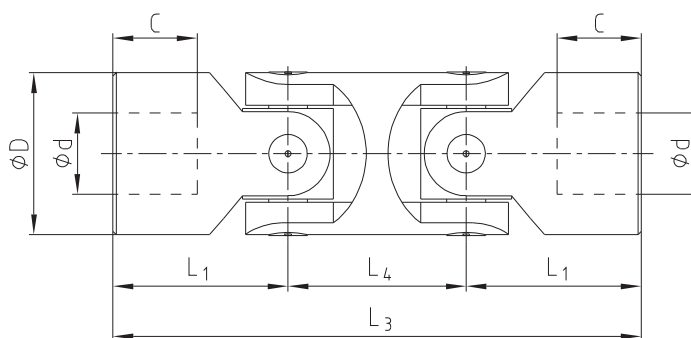
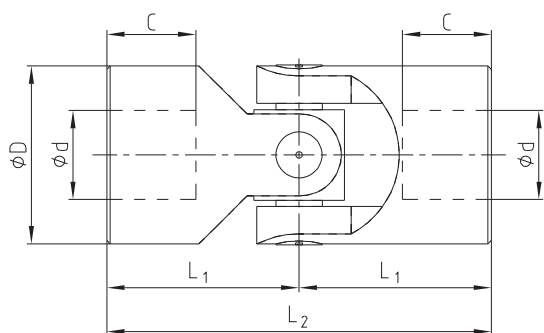

Fertigbohrungen:

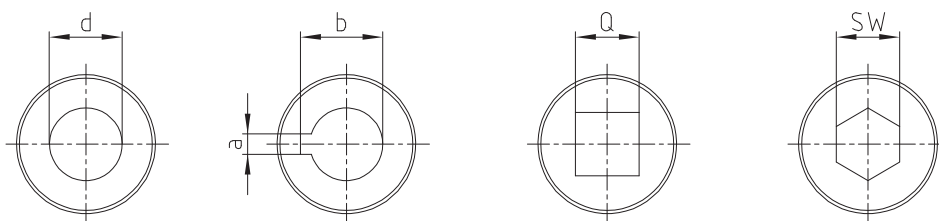

Bauart H und HD																
Bauarten und Größe				Abmessungen [mm]											Gewicht [kg]	
Größe H	DIN-Bezeichnung H	Größe HD	DIN-Bezeichnung HD	d (H7)	D	L ₂	L ₁	C	L ₄	L ₃	a (JS9)	b	Q (H10)	SW (H10)	H	HD
03 H	E10 x 22-W	03 HD	D10 x 22-W	10	22	48	24	12	26	74	3	11,4	10	10	0,10	0,15
04 H	E12 x 25-W	04 HD	D12 x 25-W	12	25	56	28	13	30	86	4	13,8	12	12	0,16	0,25
05 H	E14 x 28-W	05 HD	D14 x 28-W	14	28	60	30	14	36	96	5	16,3	14	14	0,20	0,40
1 H	E16 x 32-W	1 HD	D16 x 32-W	16	32	68	34	16	37	105	5	18,3	16	16	0,30	0,45
2 H	E18 x 36-W	2 HD	D18 x 36-W	18	36	74	37	17	40	114	6	20,8	18	18	0,45	0,70
3 H	E20 x 42-W	3 HD	D20 x 42-W	20	42	82	41	18	47	129	6	22,8	20	20	0,60	1,00
4 H	E22 x 45-W	4 HD	D22 x 45-W	22	45	95	47,5	22	50	145	6	24,8	22	22	0,95	1,55
5 H	E25 x 50-W	5 HD	D25 x 50-W	25	50	108	54	26	55	163	8	28,3	25	25	1,20	2,00
6 H	E30 x 58-W	6 HD	D30 x 58-W	30	58	122	61	29	68	190	8	33,3	30	30	1,85	2,90
6 H1	E32 x 58-W	6 HD1	D32 x 58-W	32	58	130	65	33	68	198	10	35,3	30	30	2,00	3,00
7 H	E35 x 70-W	7 HD	D35 x 70-W	35	70	140	70	33	72	212	10	38,3	-	-	3,15	4,75
8 H	E40 x 80-W	8 HD	D40 x 80-W	40	80	160	80	38	85	245	12	43,3	-	-	4,60	7,20
9 H	E50 x 95-W	9 HD	D50 x 95-W	50	95	190	95	46	100	290	14	53,8	-	-	7,60	12,0

Bestell- beispiel:	1 H	Ø16	Ø16 Nute DIN
	Wellengelenkgröße/-bauart	Fertigbohrung (H7)	Fertigbohrung (H7), Passfedernute nach DIN 6885 Bl. 1 (JS9)